

NOTES:

1. THESE DRAWINGS ARE THE PROPERTY OF FIBERGLASS SPECIALTIES INC. AND MAY NOT BE REPRODUCED WITHOUT EXPRESS WRITTEN PERMISSION FROM FIBERGLASS SPECIALTIES, INC.
2. DIMENSIONS AND DETAILS ARE SUBJECT TO CHANGE WITHOUT NOTICE.
3. ALL CUPOLA AND STEEPLE UNITS ARE FABRICATED USING MINIMAL STANDING SEAMS UNLESS OTHERWISE NOTED. SEE SECTION VIEWS FOR APPROXIMATE LOCATION OF SEAMS.
4. ALL CUPOLA AND STEEPLE UNITS ARE DESIGNED TO BE ERECTED ON A COMPLETED ROOFING SYSTEM.
5. ALTHOUGH OUR CUPOLAS AND STEEPLES ARE WATER RESISTANT WE DO NOT GUARANTEE THEM TO BE LEAK PROOF.
6. FIBERGLASS SPECIALTIES INC. RECOMMENDS THAT THE INSTALLER USE A-325 BOLTS WHEN CONNECTING TO THE ROOF STRUCTURE BELOW.
7. ACTUAL ANCHOR BOLT LOCATIONS MAY VARY. THE INSTALLER SHOULD NOT DRILL HOLES IN ROOF UNTIL UNIT IS ON SITE.
8. DUE TO MANUFACTURING TOLERANCES AND VARIATIONS IN SITE CONDITIONS, METAL SHIMS MAY BE REQUIRED BETWEEN ADJACENT COLLARS.

DESIGN PARAMETERS

The unit described in these drawings is engineered to adequately support the loads created by a wind velocity of 120 MPH at a height of 50' above ground using ASCE 7-95 exposure category "C". An additional 2' in height was added to the base during these calculations to account for variations in roof pitch, etc. For complete construction details please reference drawing number S1E.

P.O. BOX 1340  
HENDERSON, TX 75653-1340  
903/657-6522  
FAX# 903/657-2318

FIBERGLASS  
SPECIALTIES  
INCORPORATED

CUPOLA UNIT #1300  
CROSS SECTION SHOWING  
INTERNAL STRUCTURE

Project:

Date: 07-11-01  
Revisions 12-19-05 AGT

Drawing By: JC  
Checked By: ALL-STL

File #  
DWG #

Scale: NONE

Sheet #

S1C  
STRUCTURE

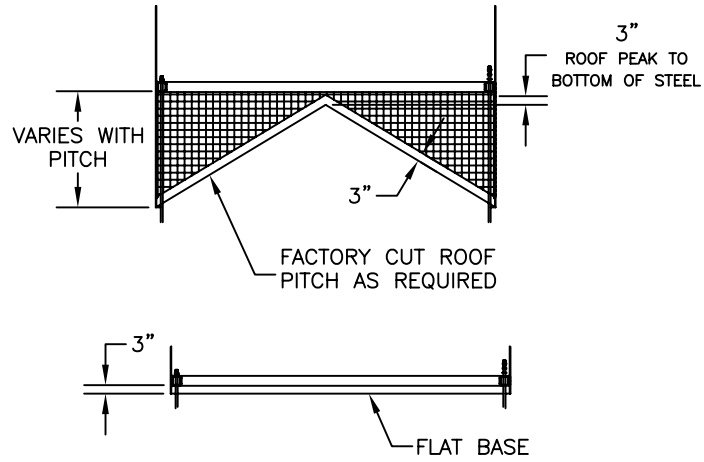

5  
S1  
BASE DETAILS

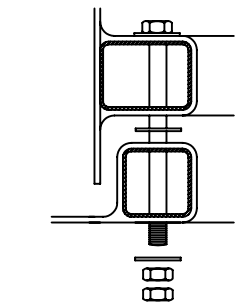

4  
S1  
BOLTING DETAIL

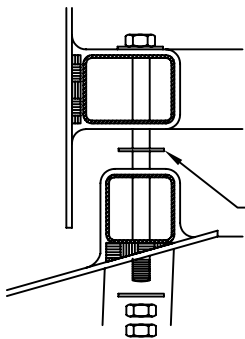

3  
S1  
BOLTING DETAIL

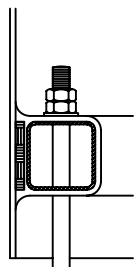

2  
S1  
ANCHOR DETAIL

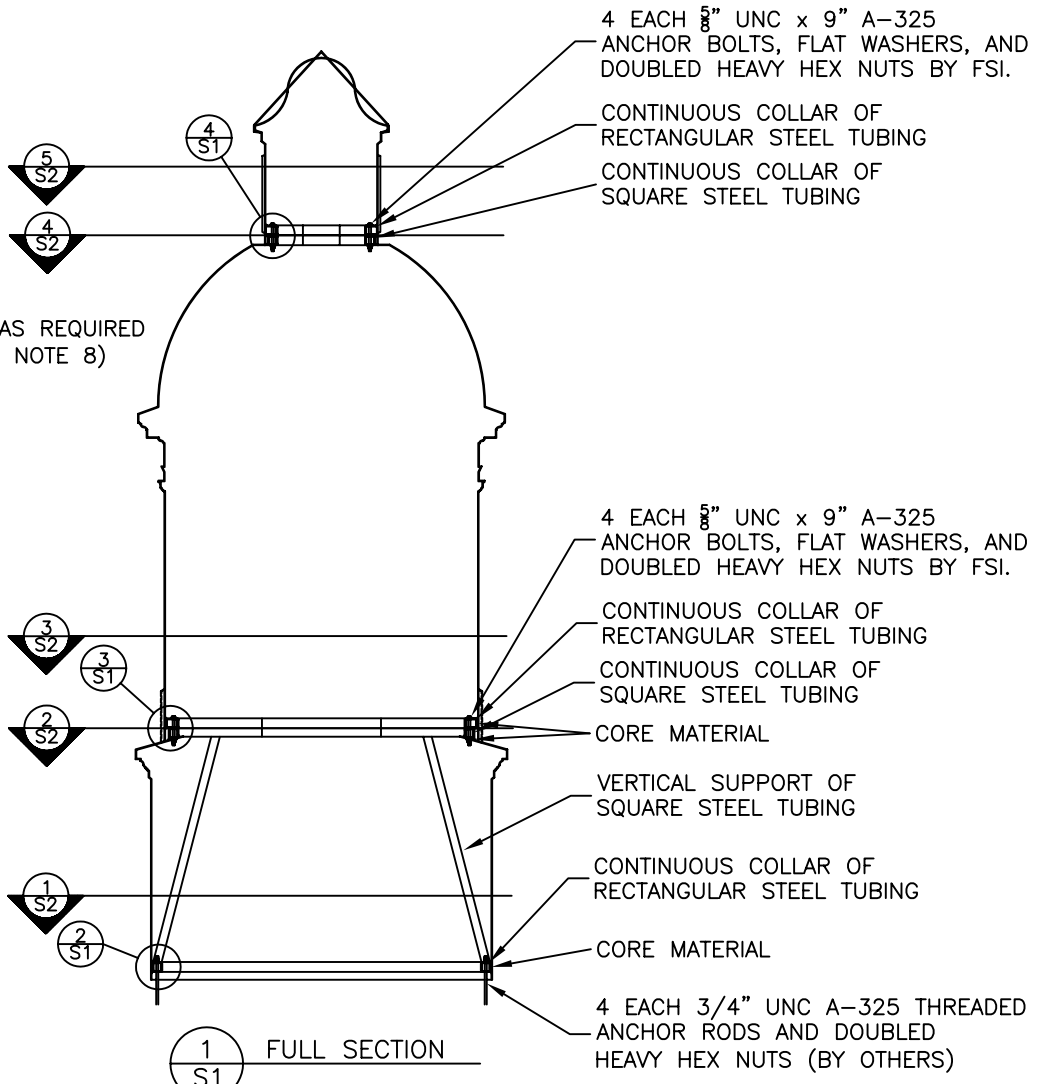

1  
S1  
FULL SECTION