

2 TOP OF CU-604
S2

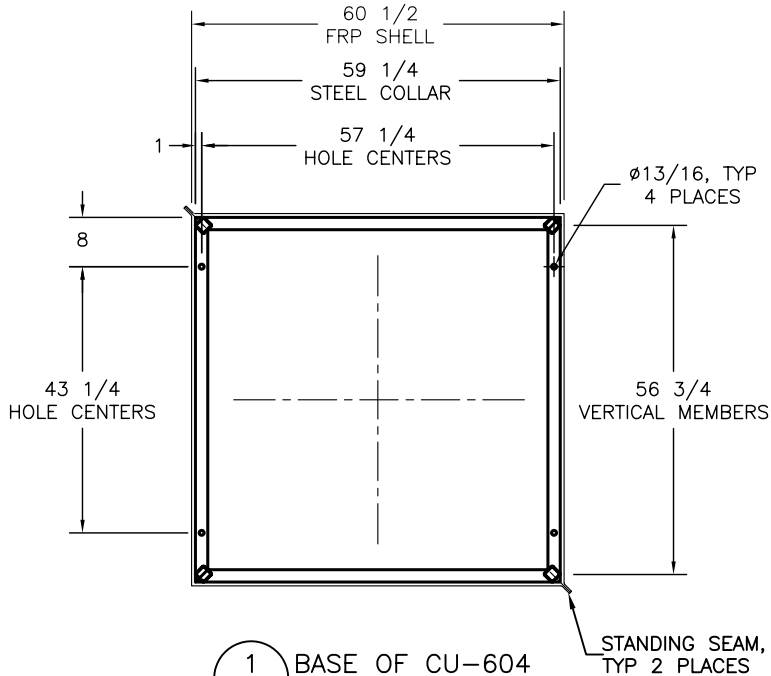

1 BASE OF CU-604
S2 PLAN VIEW

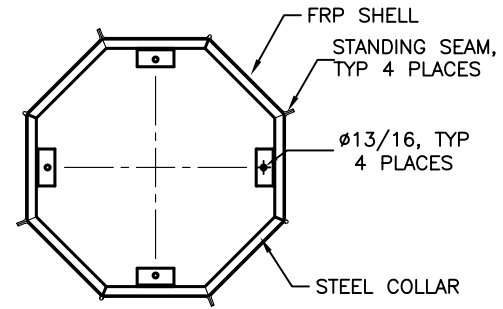

5 BASE OF DM-603
S2 PLAN VIEW

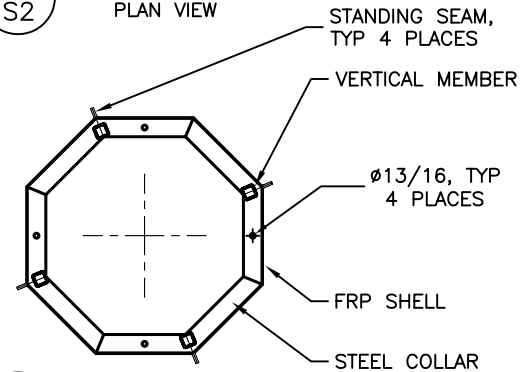

4 TOP OF CU-603
S2

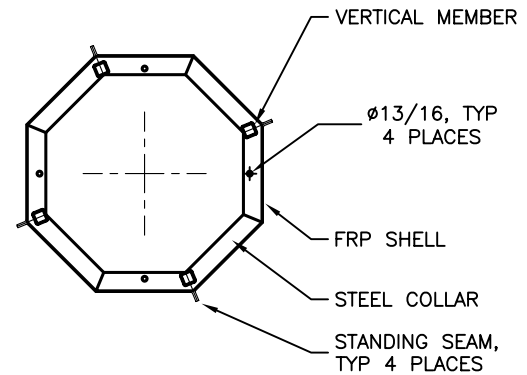

3 BASE OF CU-603
S2 PLAN VIEW

| | | | |
|-----------|--------|-----------------|-----------------------|
| STRUCTURE | Sheet# | Drawing By: JC | Date: 07-11-01 |
| | | Checked By: | Revisions 04-06-07 AJ |
| | | File # ALL-STL\ | |
| | | DWG # CU1107C2 | Scale: 3/8"=1' |

Project: CUPOLA UNIT # 1107
SECTION DETAILS

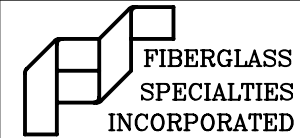

P.O. BOX 1340
HENDERSON, TX 75653-1340
903/657-6522
FAX# 903/657-2318