

NOTES:

1. THESE DRAWINGS ARE THE PROPERTY OF FIBERGLASS SPECIALTIES INC. AND MAY NOT BE REPRODUCED WITHOUT EXPRESS WRITTEN PERMISSION FROM FIBERGLASS SPECIALTIES, INC.
2. DIMENSIONS AND DETAILS ARE SUBJECT TO CHANGE WITHOUT NOTICE.
3. ALL CUPOLA AND STEEPLE UNITS ARE FABRICATED USING MINIMAL STANDING SEAMS UNLESS OTHERWISE NOTED. SEE SECTION VIEWS FOR APPROXIMATE LOCATION OF SEAMS.
4. ALL CUPOLA AND STEEPLE UNITS ARE DESIGNED TO BE ERECTED ON A COMPLETED ROOFING SYSTEM.
5. ALTHOUGH OUR CUPOLAS AND STEEPLES ARE WATER RESISTANT WE DO NOT GUARANTEE THEM TO BE LEAK PROOF.
6. FIBERGLASS SPECIALTIES INC. RECOMMENDS THAT THE INSTALLER USE A-325 BOLTS WHEN CONNECTING TO THE ROOF STRUCTURE BELOW.
7. ACTUAL ANCHOR BOLT LOCATIONS MAY VARY. THE INSTALLER SHOULD NOT DRILL HOLES IN ROOF UNTIL UNIT IS ON SITE.
8. DUE TO MANUFACTURING TOLERANCES AND VARIATIONS IN SITE CONDITIONS, METAL SHIMS MAY BE REQUIRED BETWEEN ADJACENT COLLARS.

P.O. BOX 1340  
 HENDERSON, TX 75653-1340  
 903/657-6522  
 FAX# 903/657-2318

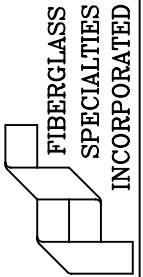

Project: STEEPLE UNIT #35  
 CROSS SECTION SHOWING  
 INTERNAL STRUCTURE

Date: 06-14-05

Revisions 02-16-06 AGT

Scale: NONE

Drawing By: TDR

Checked By:

File # ALL-STL

DWG # ST35C1

Sheet# S1C

STRUCTURE

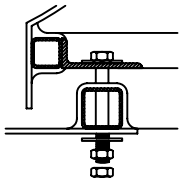
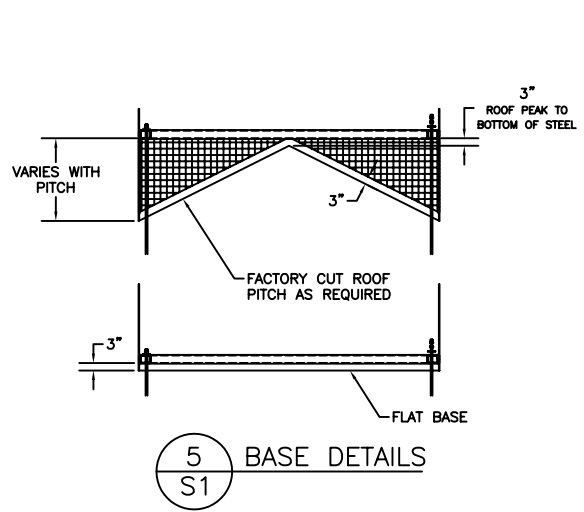

4 BOLTING DETAIL  
 S1

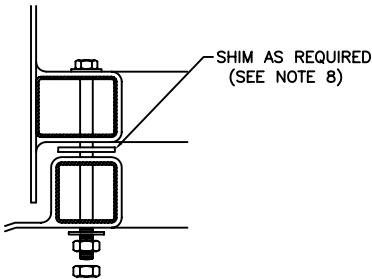

3 BOLTING DETAIL  
 S1

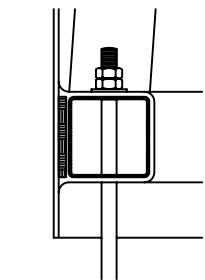

2 ANCHOR DETAIL  
 S1

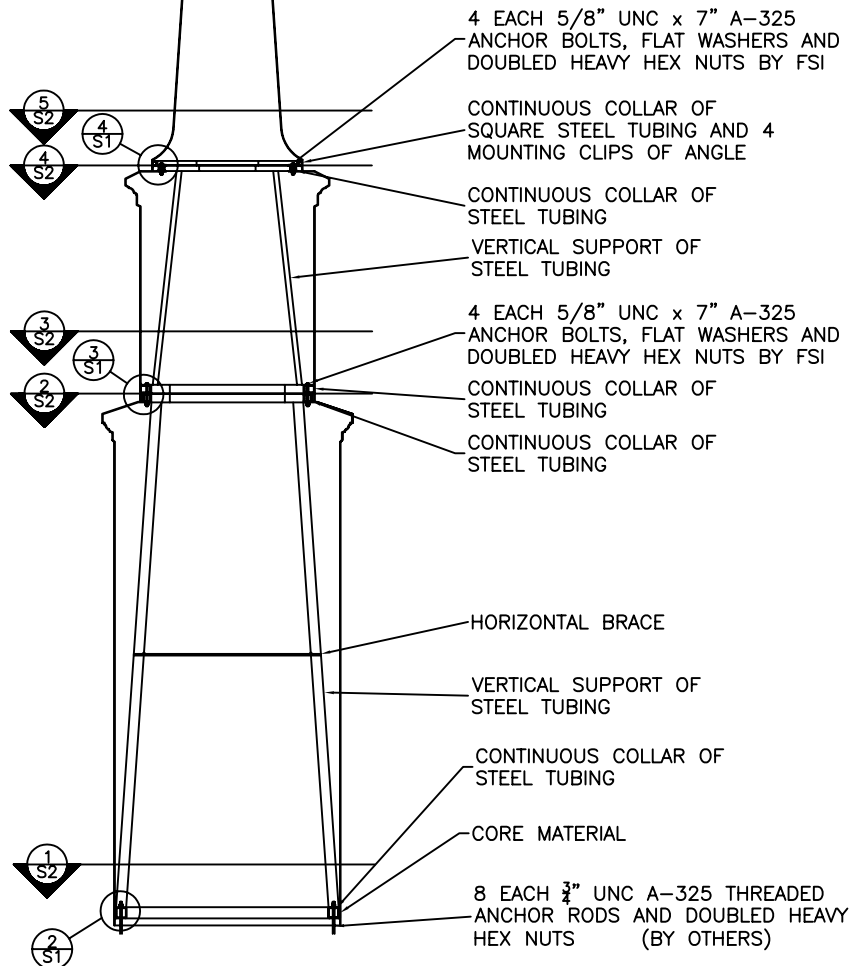

1 FULL SECTION  
 S1